



A TIMELINE OF THE WOMEN WHO CHANGED AMERICA

1700 1800 1900 2000
CHARLOTTE S. WAISMAN & JILL S. TIETJEN *Foreword by* MADELEINE ALBRIGHT



Her Story: A Timeline of the Women Who Changed America



Women Taking the Lead to Save Our Planet



Her Story: A Timeline of the Women Who Changed America

1757

Jane Colden

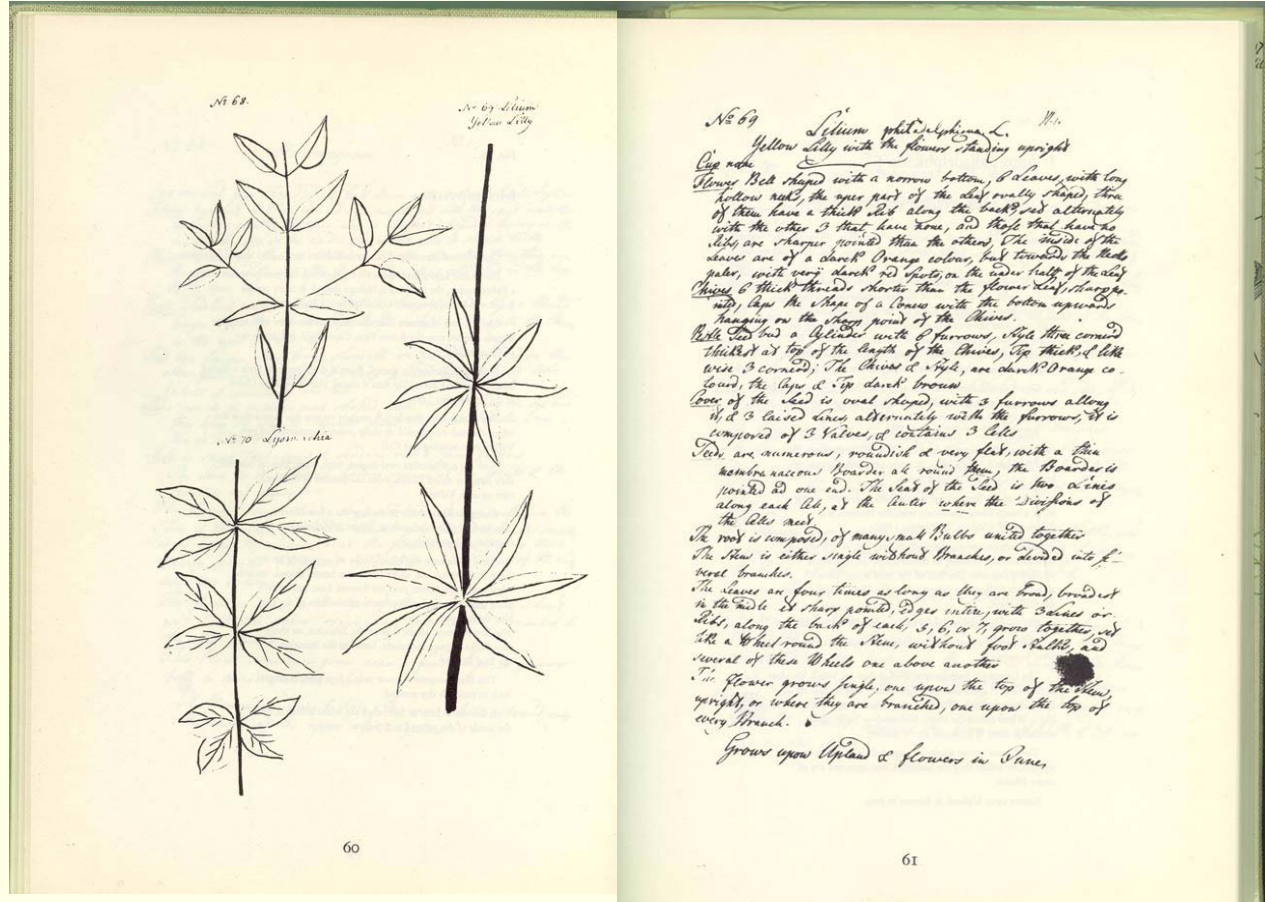

Her Story: A Timeline of the Women Who Changed America

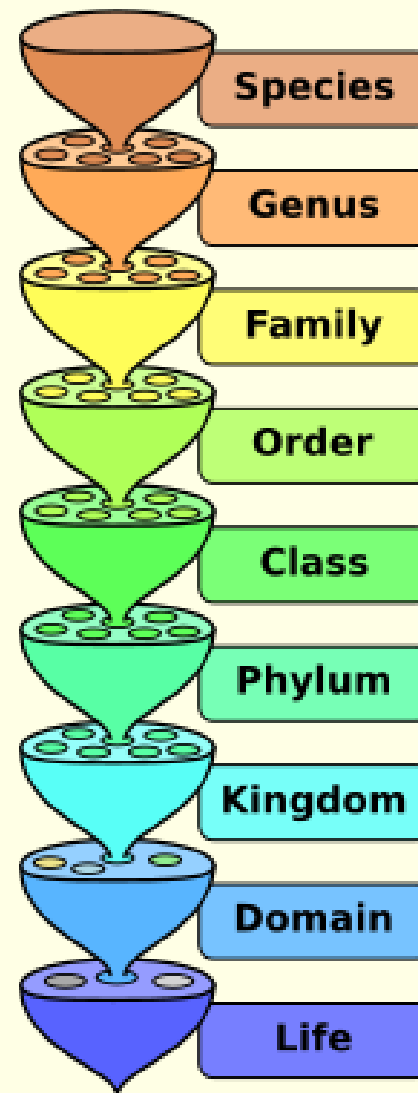

Her Story: A Timeline of the Women Who Changed America



1833



Maria Martin Bachman

Her Story: A Timeline of the Women Who Changed America

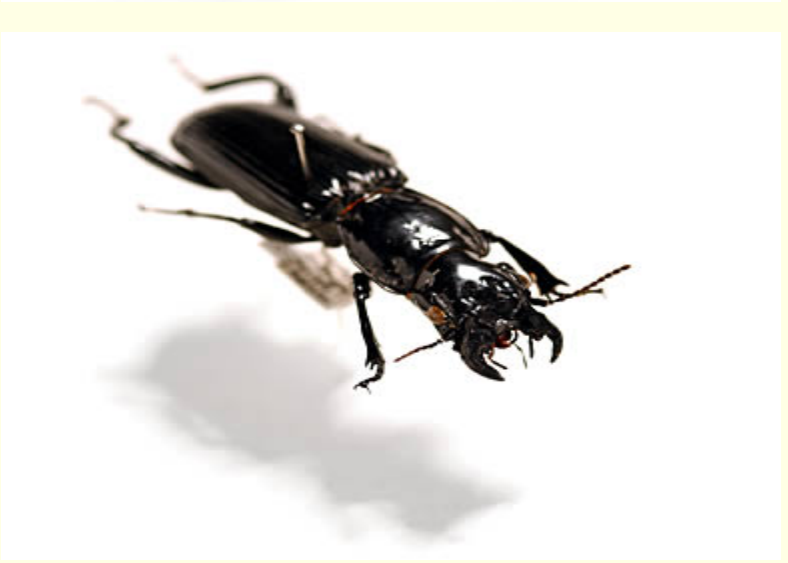

Her Story: A Timeline of the Women Who Changed America

1882

*Ellen Swallow
Richards*



Her Story: A Timeline of the Women Who Changed America

| | | | | | |
|----------------|------------------|----------------|------------------|---------------------|------------------|
| Item | Cadmium | Total cyanide | Lead | Hexavalent chromium | Arsenic |
| Standard value | 0.01mg/ℓ or less | not detectable | 0.01mg/ℓ or less | 0.05mg/ℓ or less | 0.01mg/ℓ or less |

| | | | | | |
|----------------|--------------------|----------------|----------------|------------------|----------------------|
| Item | Total-mercury | Alkyl-mercury | PCB | Dichloro-methane | Carbon tetrachloride |
| Standard value | 0.0005mg/ℓ or less | not detectable | not detectable | 0.02mg/ℓ or less | 0.002m/ℓ or less |

| | | | | | |
|----------------|--------------------|----------------------|--------------------------|-----------------------|-----------------------|
| Item | 1,2-Dichloroethane | 1,1-Dichloroethylene | Cis-1,2-Dichloroethylene | 1,1,1-Trichloroethane | 1,1,2-Trichloroethane |
| Standard value | 0.004mg/ℓ or less | 0.02mg/ℓ or less | 0.04mg/ℓ or less | 1mg/ℓ or less | 0.006mg/ℓ or less |

| | | | | | |
|----------------|--------------------|----------------------|---------------------|-------------------|-------------------|
| Item | Trichloro-ethylene | Tetrachloro-ethylene | 1,3-Dichloropropene | Thiram | Simazine |
| Standard value | 0.03mg/ℓ or less | 0.01mg/ℓ or less | 0.002mg/ℓ or less | 0.006mg/ℓ or less | 0.003mg/ℓ or less |

| | | | |
|----------------|------------------|------------------|------------------|
| Item | Thiobencarb | Benzene | Selenium |
| Standard value | 0.02mg/ℓ or less | 0.01mg/ℓ or less | 0.01mg/ℓ or less |

1887

(No Model.)
H. W. R. STRONG.
DAM AND RESERVOIR CONSTRUCTION.
No. 374,378. Patented Dec. 6, 1887.

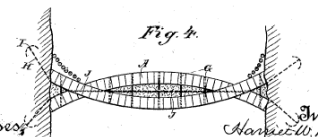
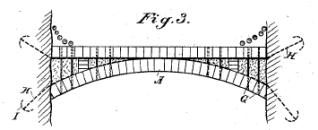
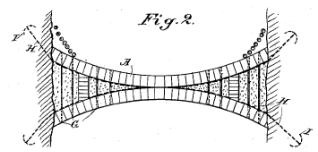
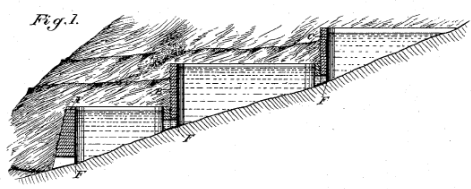

Witnesses:
Geo. H. Strong,
J. A. Ansel.
Inventor,
Harriet W. R. Strong,
By D. W. Co. atty.

A. KELSO, PHOTO-LITHOGRAPHER, WASHINGTON, D. C.

Harriet Strong

(No Model.)
H. W. R. STRONG.
METHOD OF AND MEANS FOR IMPOUNING DEBRIS AND STORING WATER.
No. 528,823. Patented Nov. 6, 1894.

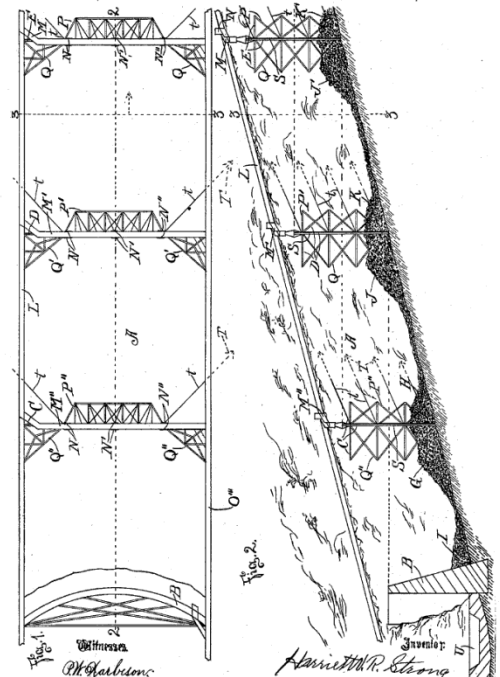

Witnesses:
W. H. Harbison,
P. M. Townsend.
Inventor,
Harriet W. R. Strong,
By Hazard Townsend,
Att'y.

THE MERRILL & CO. PHOTO-LITHOGRAPHERS, WASHINGTON, D. C.

Her Story: A Timeline of the Women Who Changed America



Her Story: A Timeline of the Women Who Changed America

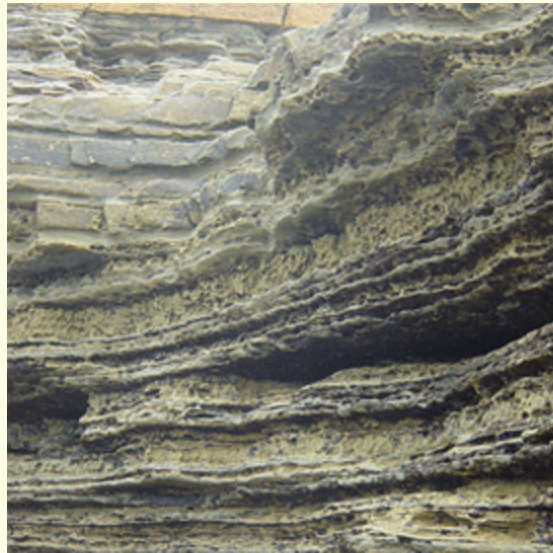

1893



Florence Bascom

Her Story: A Timeline of the Women Who Changed America

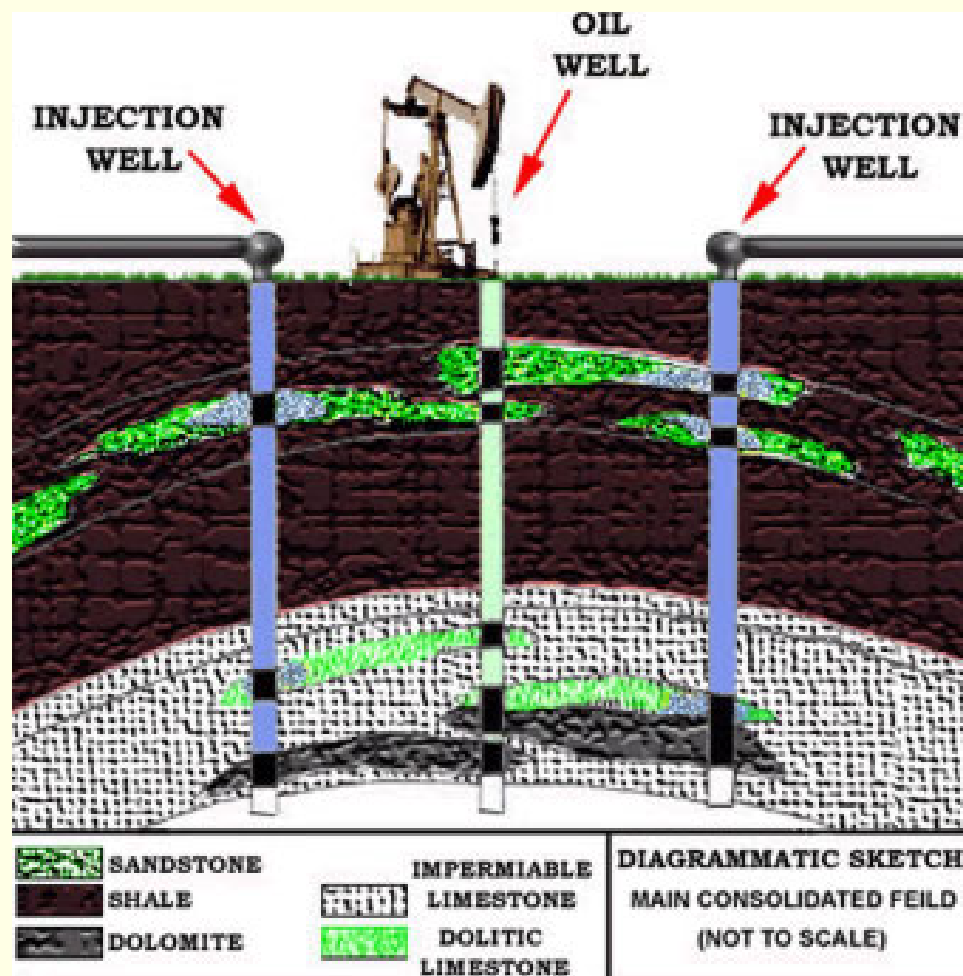



1895

Catherine Furbish



Her Story: A Timeline of the Women Who Changed America

Types of Biomass

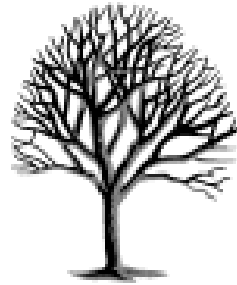

Wood

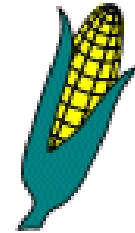

Crops



Garbage



Landfill Gas

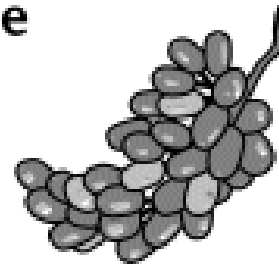

Alcohol Fuels



1895

Mary Engle Pennington



Sept. 10, 1935. M. E. PENNINGTON 2,013,896
METHOD FOR FREEZING EGGS
Filed Dec. 30, 1932 2 Sheets-Sheet 1

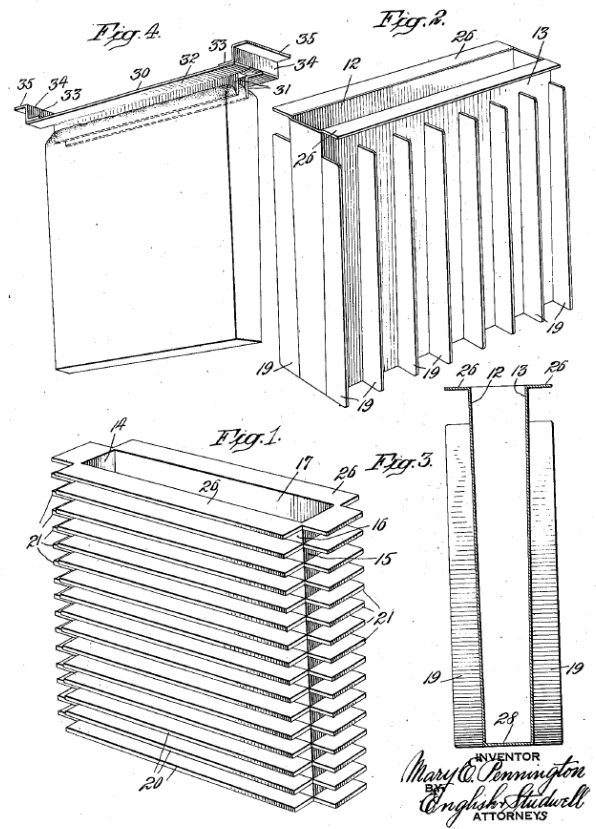

INVENTOR
Mary E. Pennington
By English & Stoddell
ATTORNEYS

Her Story: A Timeline of the Women Who Changed America



Her Story: A Timeline of the Women Who Changed America

Ruth Patrick

1933

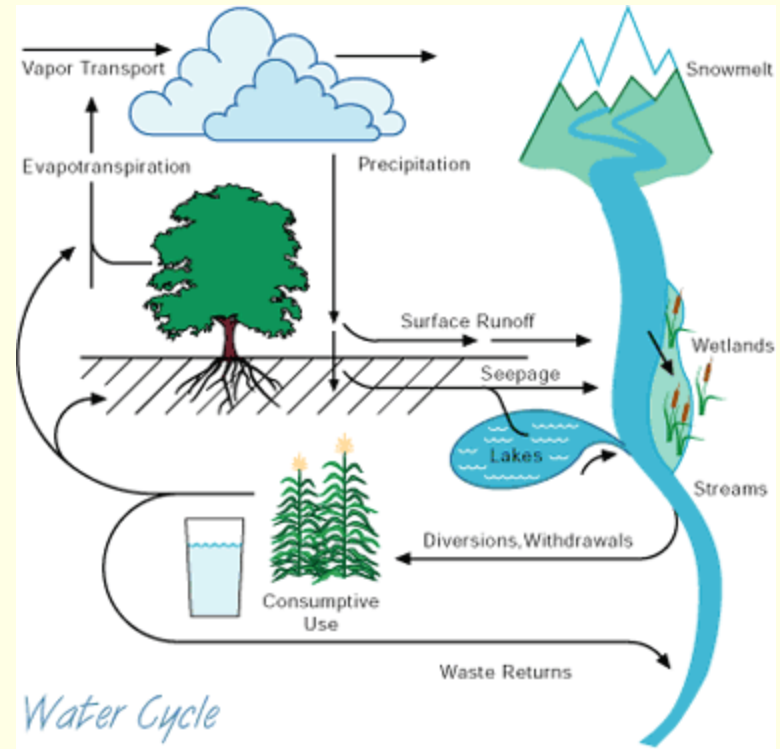

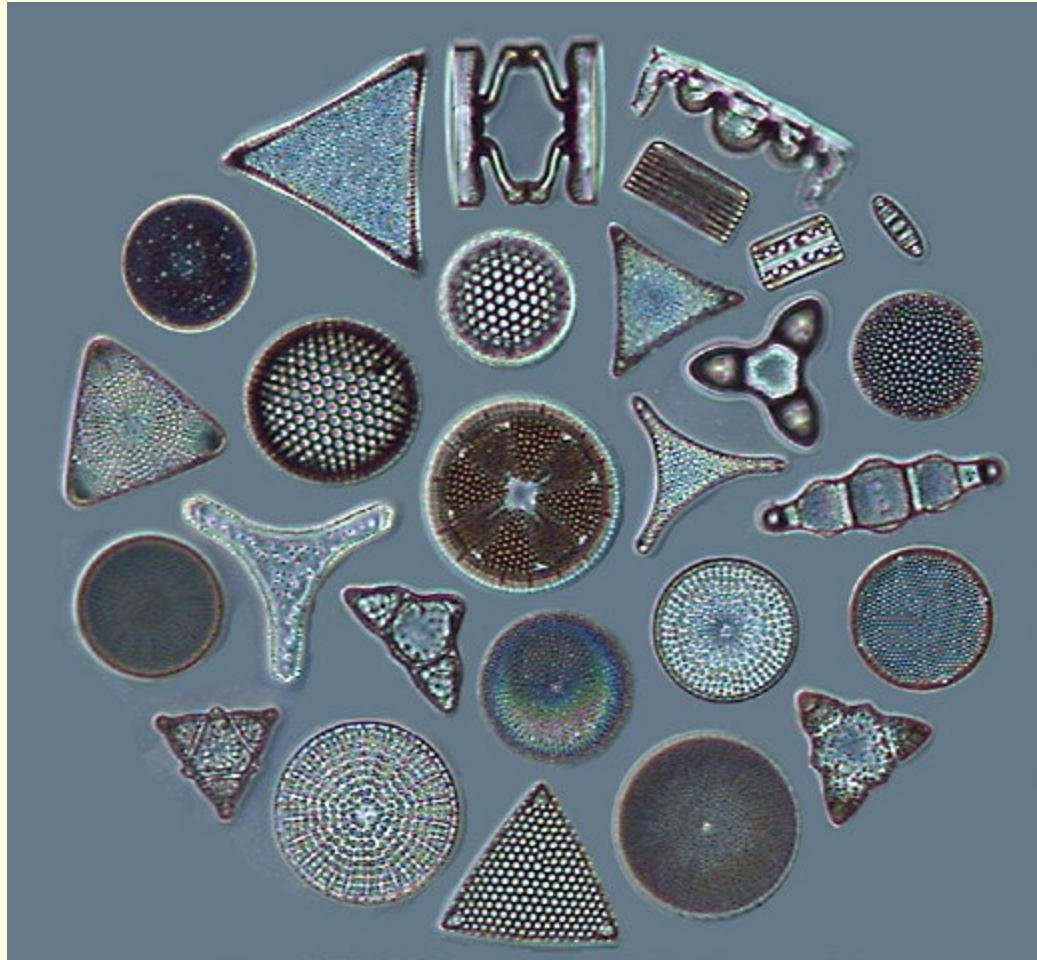

Her Story: A Timeline of the Women Who Changed America



1947



Her Story: A Timeline of the Women Who Changed America

Marjory Stoneman Douglas

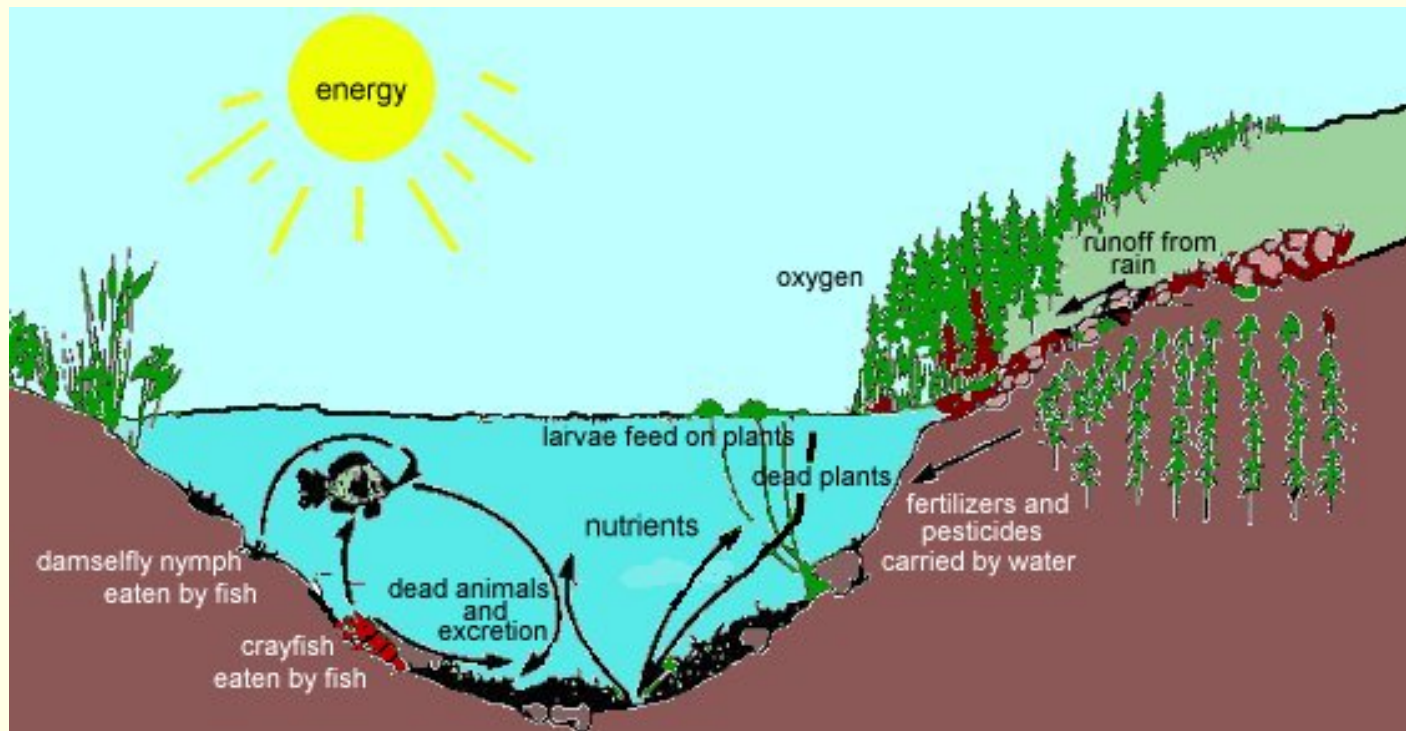

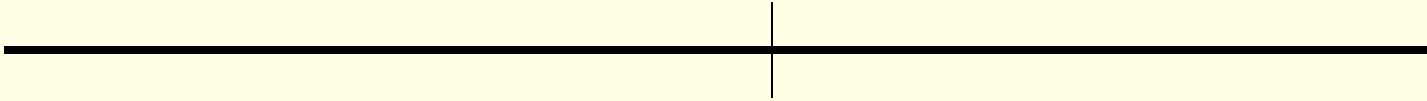

1961



Jane Jacobs



Her Story: A Timeline of the Women Who Changed America

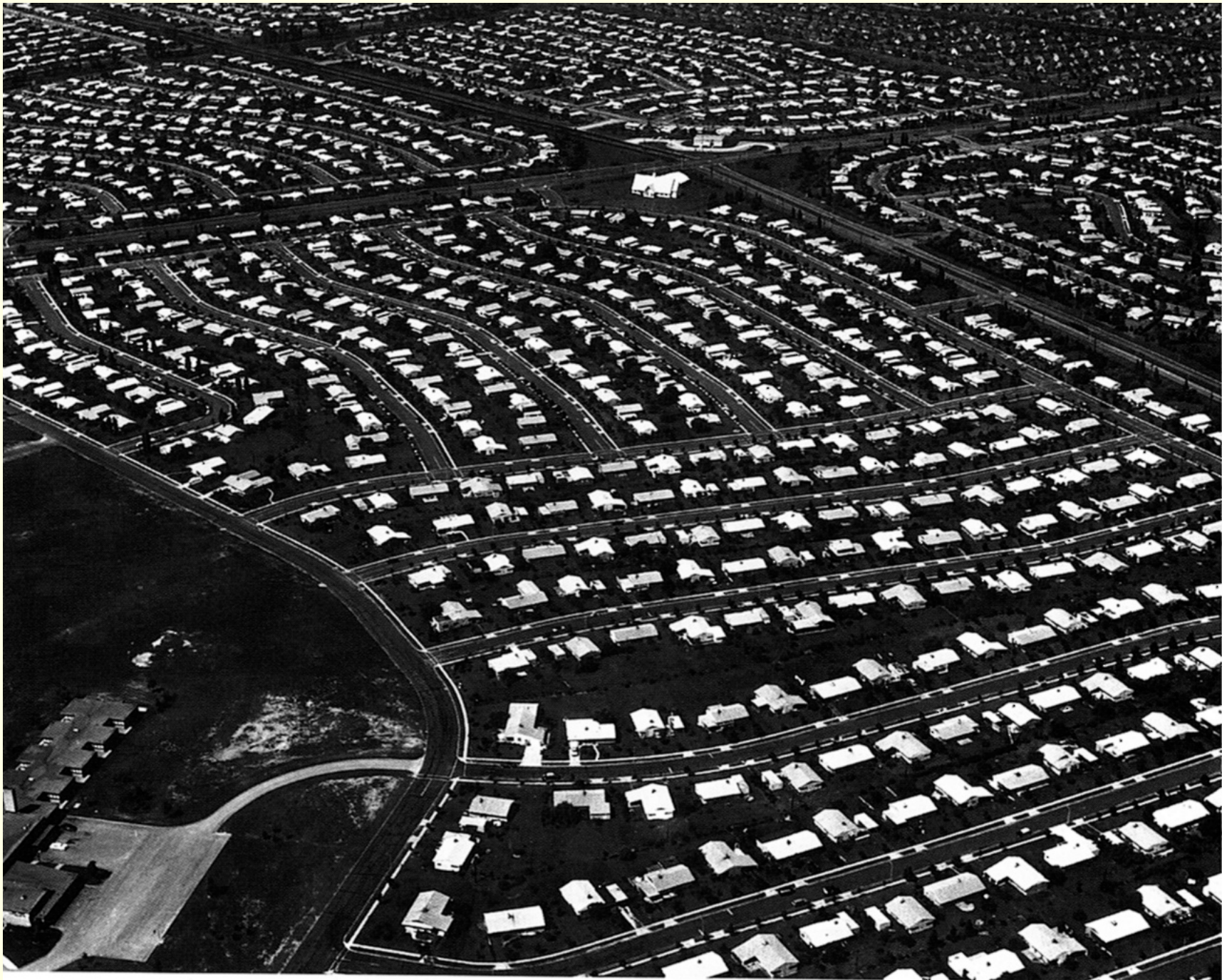

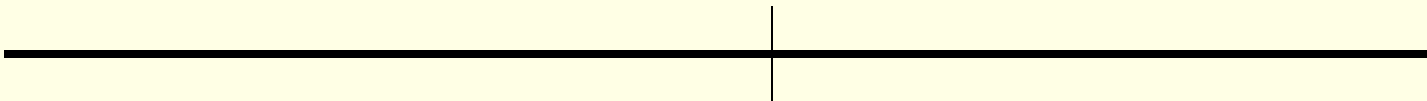

1962



Rachel Carson

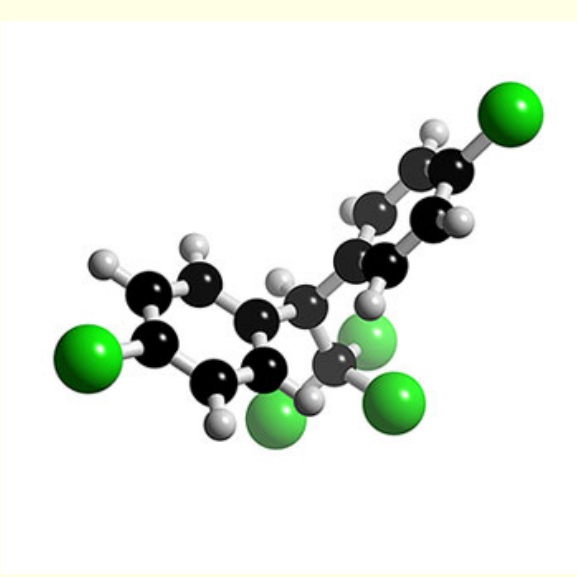
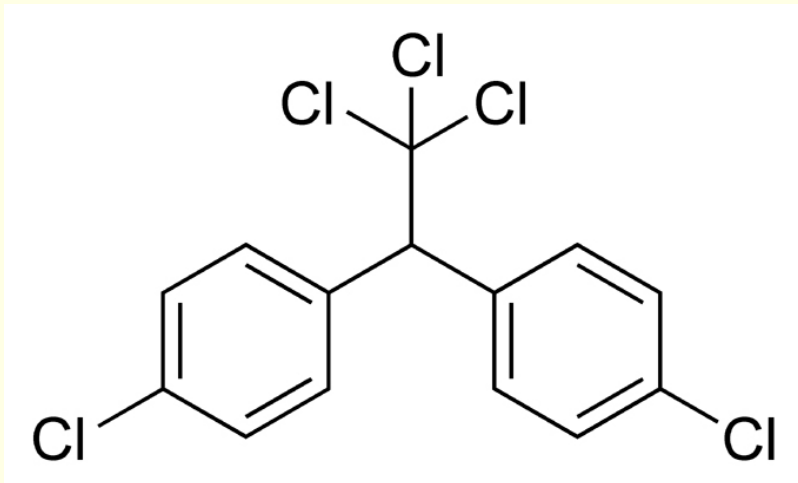

Her Story: A Timeline of the Women Who Changed America

RELATIVE IMPACT OF NONPOINT SOURCE POLLUTION PROBLEMS IN IMPAIRED WATERS

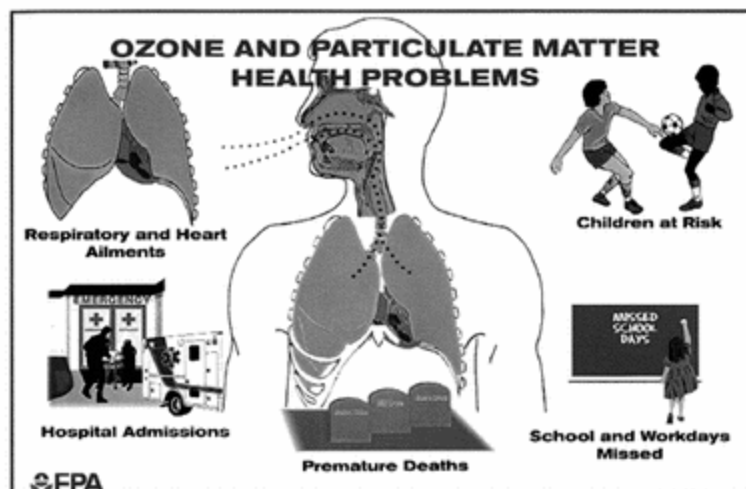
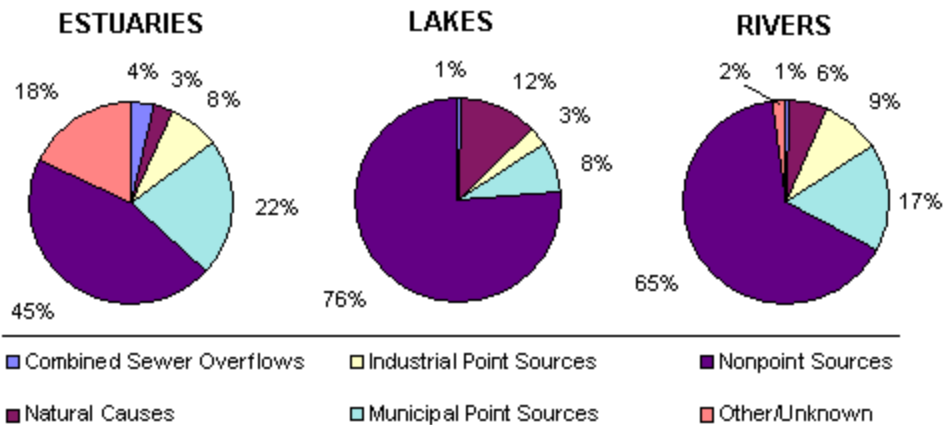



1965



Lady Bird Johnson



Her Story: A Timeline of the Women Who Changed America



State Animal



State Flower



State Butterfly and State Insect

State Bird

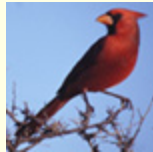

State Fish



State Grass

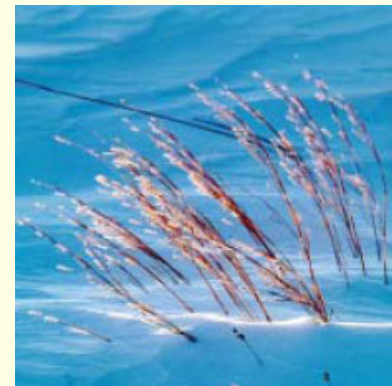



1967



Mary Sinclair

Her Story: A Timeline of the Women Who Changed America



Her Story: A Timeline of the Women Who Changed America

1967



Dian Fossey

Her Story: A Timeline of the Women Who Changed America



1984

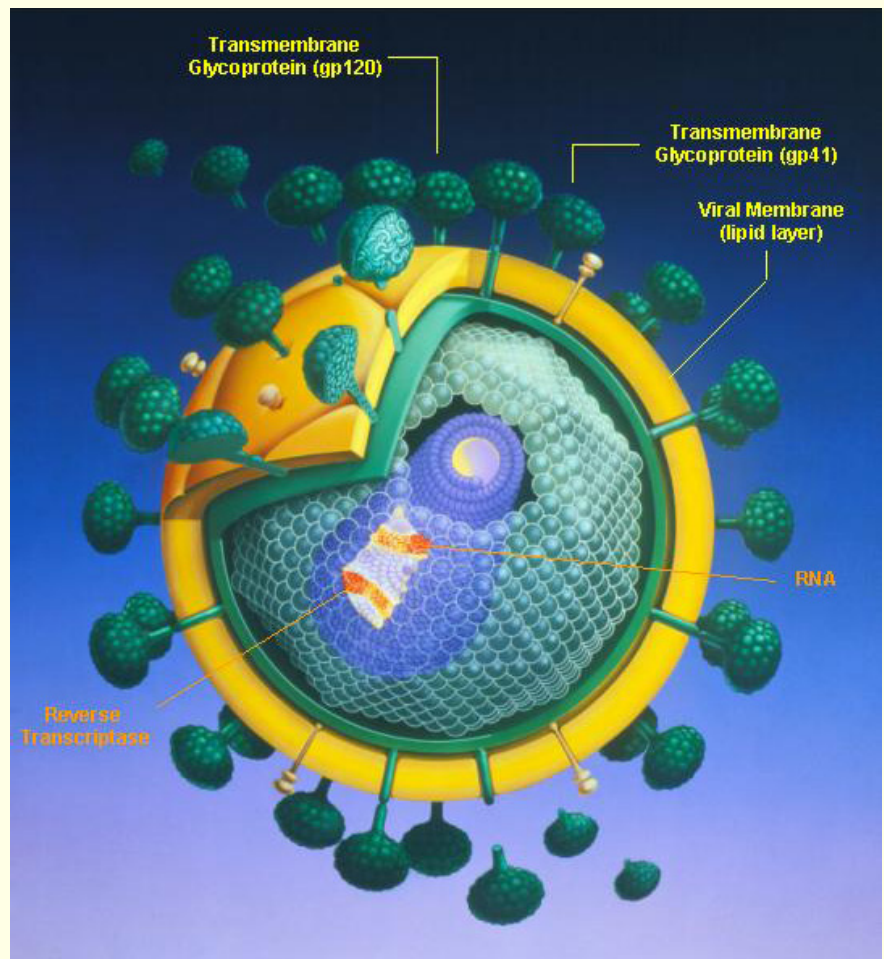
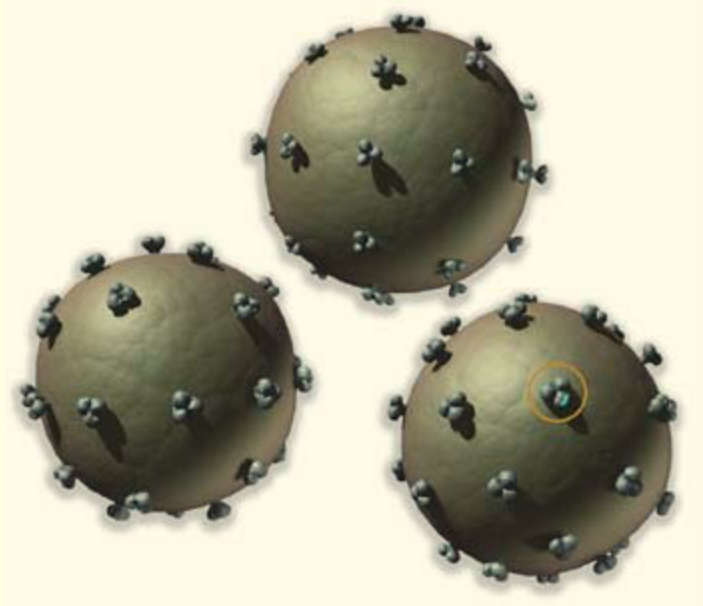

Flossie Wong-Staal

Her Story: A Timeline of the Women Who Changed America

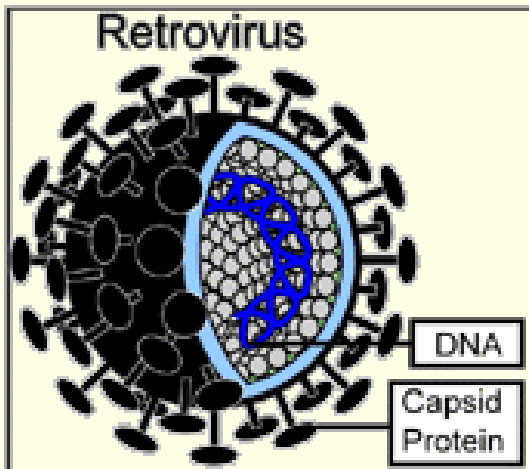
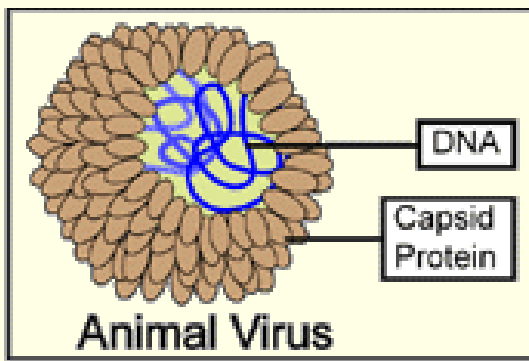
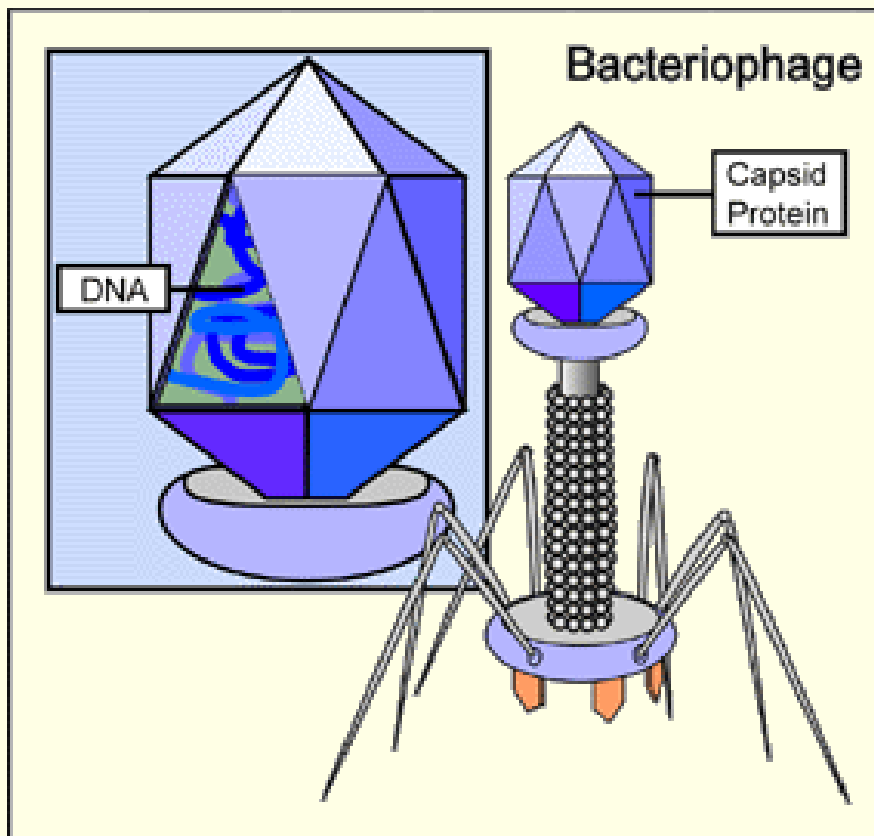



1987

Mae Jemison



Her Story: A Timeline of the Women Who Changed America

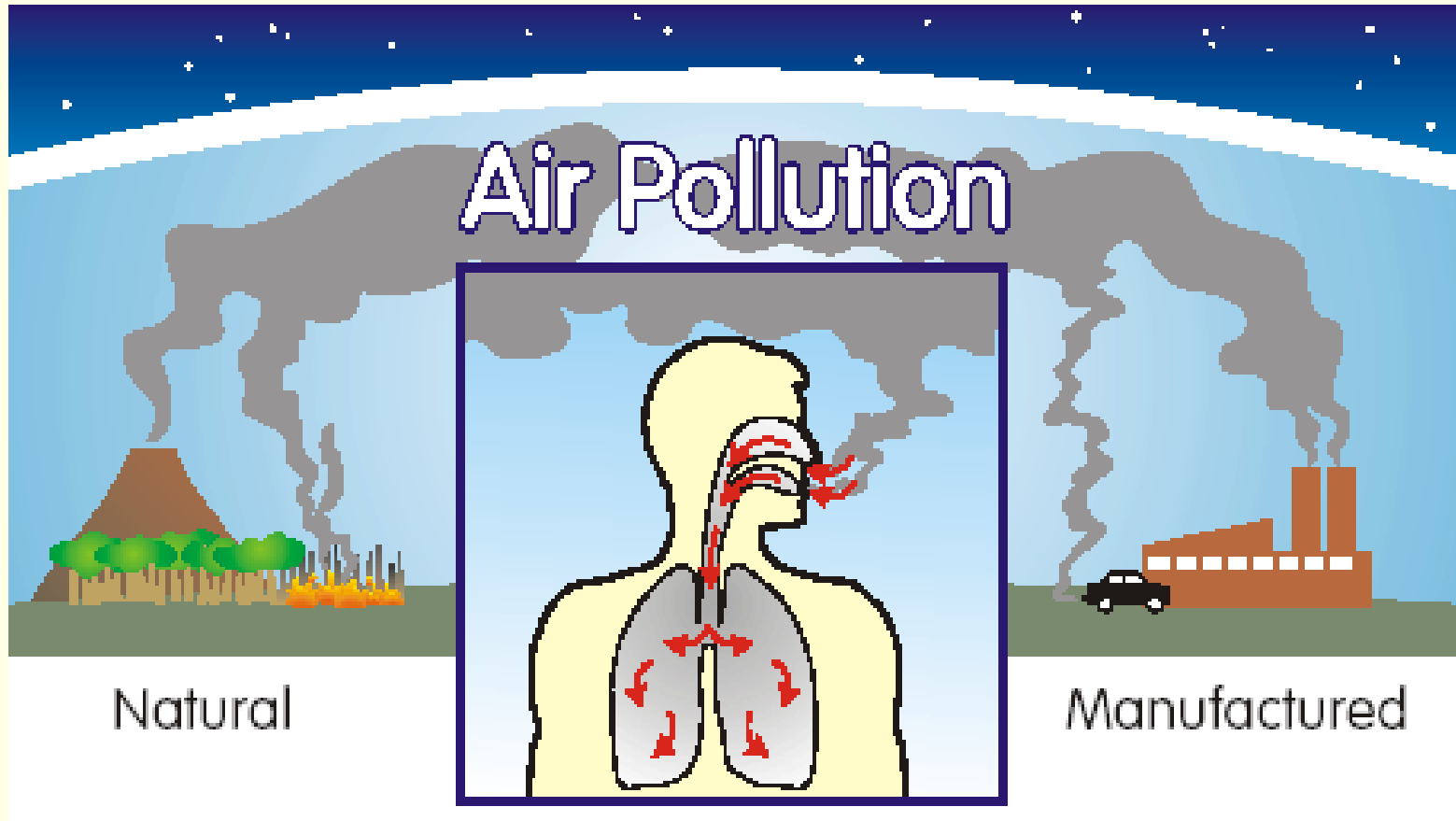



1987



The fruit of the Beavertail Cactus.



Ethnobotanical Garden

Katherine Siva Saubel



Her Story: A Timeline of the Women Who Changed America



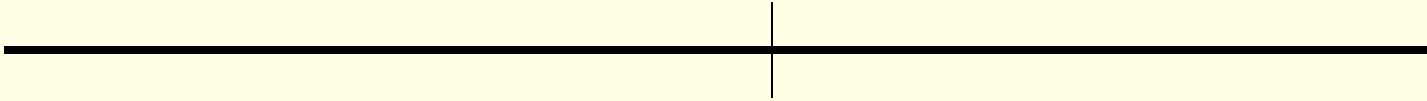

1990



Sylvia Earle



Her Story: A Timeline of the Women Who Changed America



“Never doubt that a small group of thoughtful, committed citizens can change the world. Indeed, it is the only thing that ever has.”

Margaret Mead, cultural anthropologist