



## A TIMELINE OF THE WOMEN WHO CHANGED AMERICA

1700 1800 1900 2000  
CHARLOTTE S. WAISMAN & JILL S. TIETJEN *Foreword by* MADELEINE ALBRIGHT



*Her Story: A Timeline of the Women Who Changed America*

# COMPUTERS ARE AMAZING!

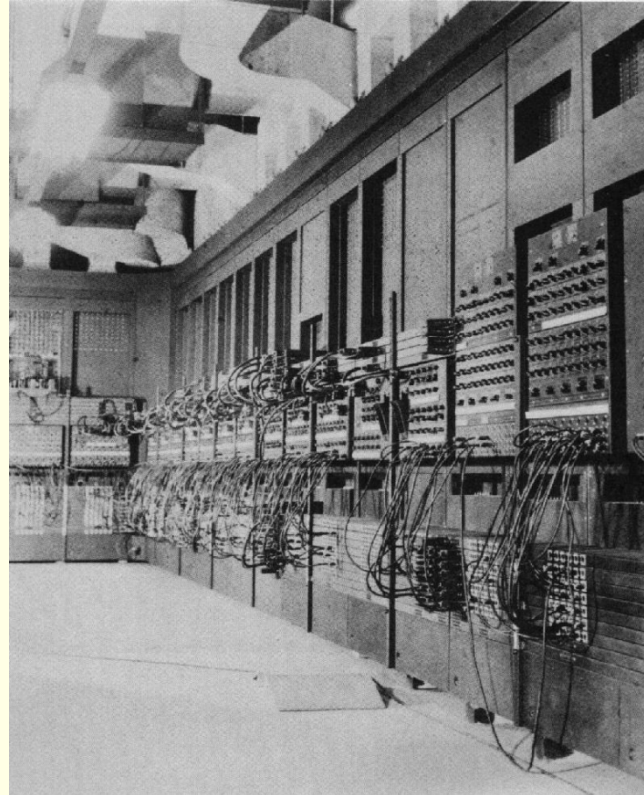
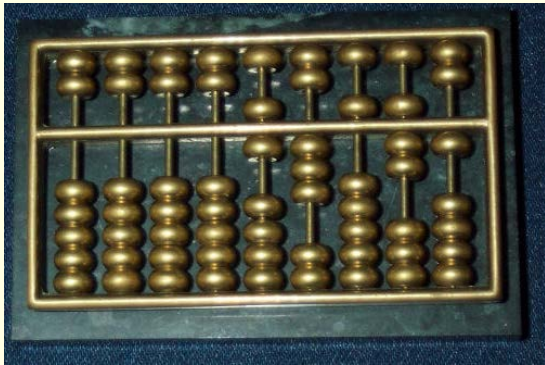

*Her Story: A Timeline of the Women Who Changed America*





$$\left( \frac{\partial L}{\partial \dot{q}} \cdot \dot{q} - L \right) T_r - \frac{\partial L}{\partial q} \cdot Q_r$$

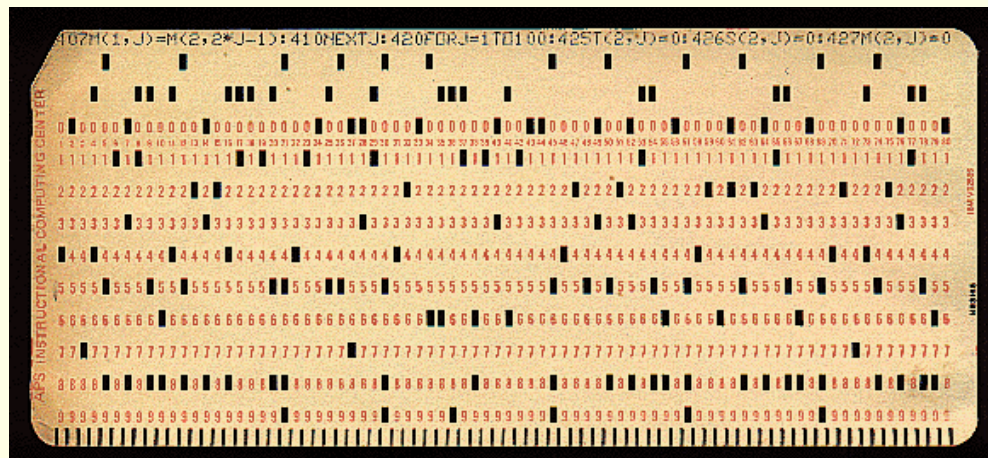
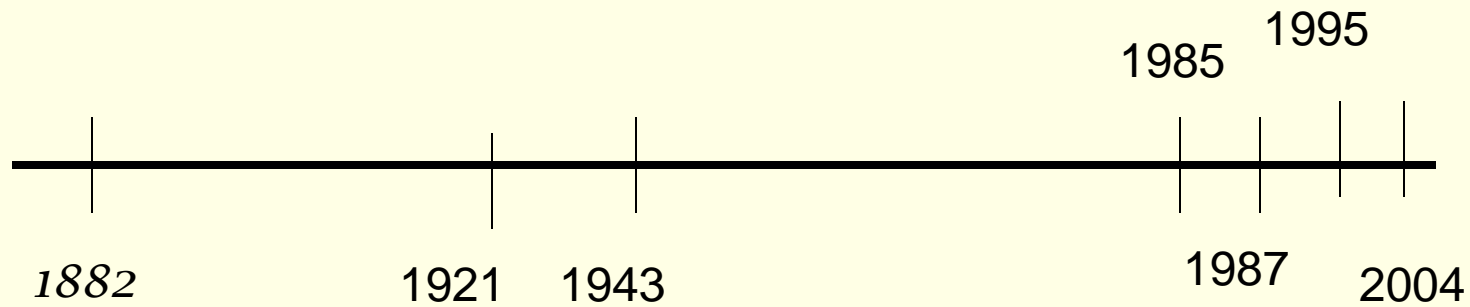

1882

*Christine Ladd-Franklin*

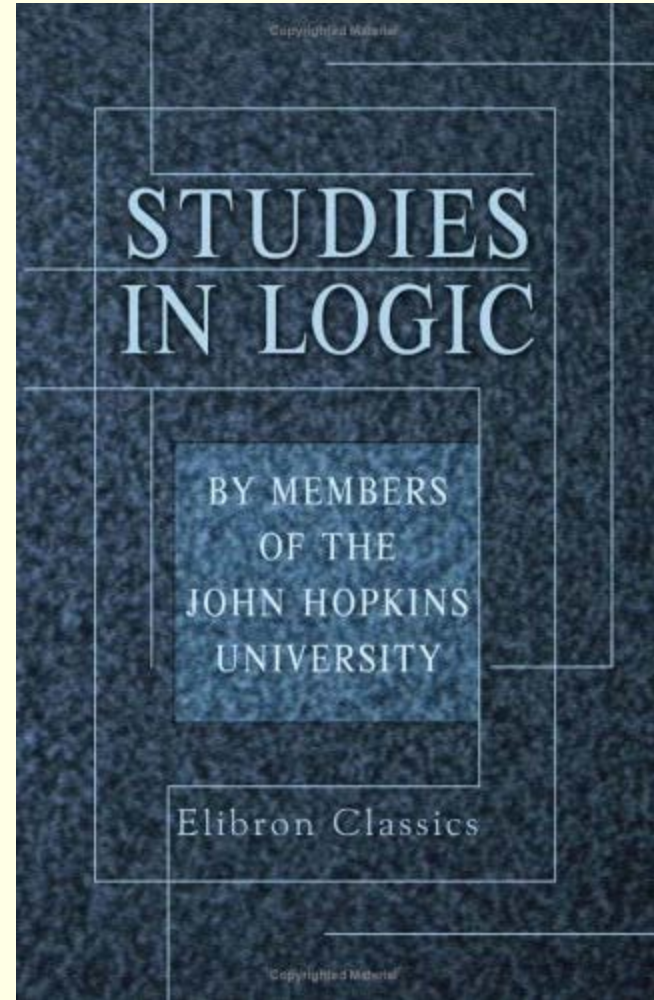

*Her Story: A Timeline of the Women Who Changed America*



Decimal	Binary
0	0
1	1
2	10
3	11
4	100
5	101
6	110
7	111
8	1000
9	1001
10	1010
11	1011



---

1921

# Emmy Noether- Programm

Deutsche  
Forschungsgemeinschaft

**DFG**



$$\left( \frac{\partial L}{\partial \dot{\mathbf{q}}} \cdot \dot{\mathbf{q}} - L \right) T_r - \frac{\partial L}{\partial \dot{\mathbf{q}}} \cdot \mathbf{Q}_r$$

*Amalie Emmy Noether*

*Her Story: A Timeline of the Women Who Changed America*



x	1	2	3	4	5	6	7	8	9	A	B	C	D	E	F	10
1	1	2	3	4	5	6	7	8	9	A	B	C	D	E	F	10
2	2	4	6	8	A	C	E	10	12	14	16	18	1A	1C	1E	20
3	3	6	9	C	F	12	15	18	1B	1E	21	24	27	2A	2D	30
4	4	8	C	10	14	18	1C	20	24	28	2C	30	34	38	3C	40
5	5	A	F	14	19	1E	23	28	2D	32	37	3C	41	46	4B	50
6	6	C	12	18	1E	24	2A	30	36	3C	42	48	4E	54	5A	60
7	7	E	15	1C	23	2A	31	38	3F	46	4D	54	5B	62	69	70
8	8	10	18	20	28	30	38	40	48	50	58	60	68	70	78	80
9	9	12	1B	24	2D	36	3F	48	51	5A	63	6C	75	7E	87	90
A	A	14	1E	28	32	3C	46	50	5A	64	6E	78	82	8C	96	A0
B	B	16	21	2C	37	42	4D	58	63	6E	79	84	8F	9A	A5	B0
C	C	18	24	30	3C	48	54	60	6C	78	84	90	9C	A8	B4	C0
D	D	1A	27	34	41	4E	5B	68	75	82	8F	9C	A9	B6	C3	D0
E	E	1C	2A	38	46	54	62	70	7E	8C	9A	A8	B6	C4	D2	E0
F	F	1E	2D	3C	4B	5A	69	78	87	96	A5	B4	C3	D2	E1	F0
10	10	20	30	40	50	60	70	80	90	A0	B0	C0	D0	E0	F0	100

Hexadecimal	Binary	Decimal
0	0000	0
1	0001	1
2	0010	2
3	0011	3
4	0100	4
5	0101	5
6	0110	6
7	0111	7
8	1000	8
9	1001	9
A	1010	10
B	1011	11
C	1100	12
D	1101	13
E	1110	14
F	1111	15

*Her Story: A Timeline of the Women Who Changed America*





---

1943

*Admiral Grace Murray Hopper*





1943

# Admiral Grace Murray Hopper

Photo # NH 96566-KN First Computer "Bug", 1945

9/2

9/9

0800 Antcom started  
1000 " stopped - antcom ✓  
13<sup>00</sup> MC (033) MP-MC 1.582140000  
(033) PRO 2 2.130476415  
convd 2.130676415

Relays 6-2 in 033 failed special speed test  
in Relay " 10,000 test.

Relays changed

1100 Started Cosine Tape (Sine check)  
1525 Started Multi-Adder Test.

1545

Relay #70 Panel F  
(moth) in relay.



First actual case of bug being found.

1630 Antcom started.  
1700 closed down.

Relay  
2145  
Relay 3376

1943

*Admiral Grace Murray Hopper*



*Her Story: A Timeline of the Women Who Changed America*



addresses	0	1	2	3	4	5	6	7	8	9
10	T	1	6		2	6	H	8	5	I
20	4	2			1	9	C	10	7	W
30	3	5		2	9	O	4	5	S	F
40	F		S	8	0	R	5	3	A	
50	W	5	8	K	3	8		Q		7
60	7	L		U	6	6	T	7	4	
70	7	M	10	3	E	9	5	A	1	3
80		8	9	F	F	I	10	0		H
90	9	2	O	5	0	R	3	2		
100	S	2	3	P	6	3		O	7	1

*Her Story: A Timeline of the Women Who Changed America*



---

1943

*Euphemia Lofton Haynes*



*Her Story: A Timeline of the Women Who Changed America*



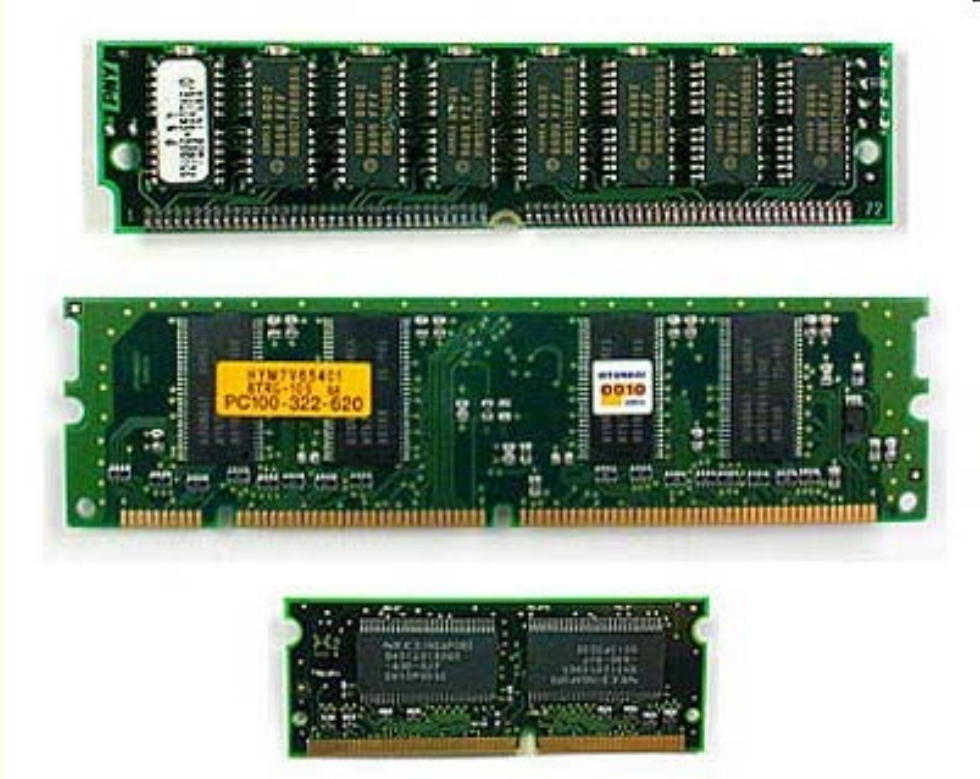

*Her Story: A Timeline of the Women Who Changed America*



1985

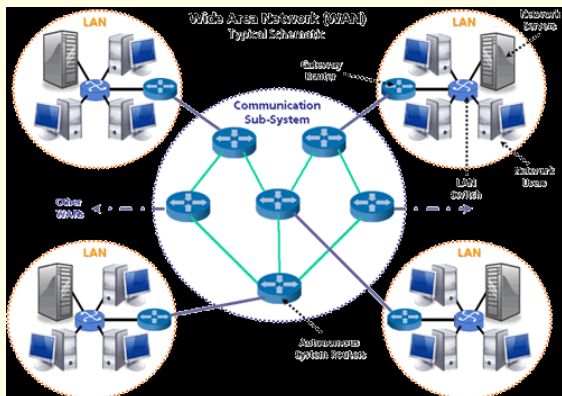
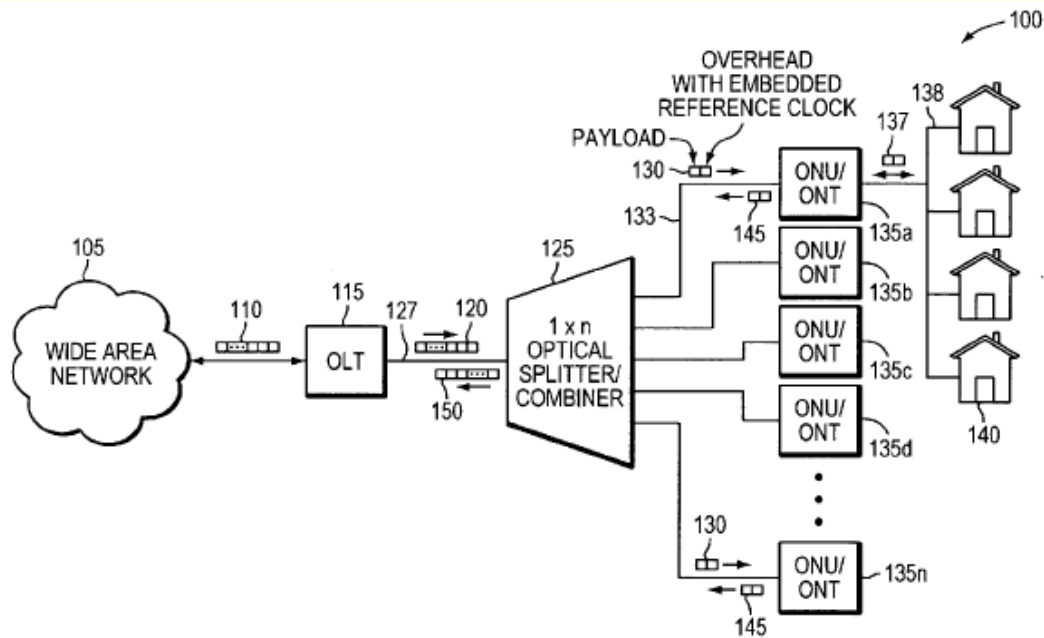
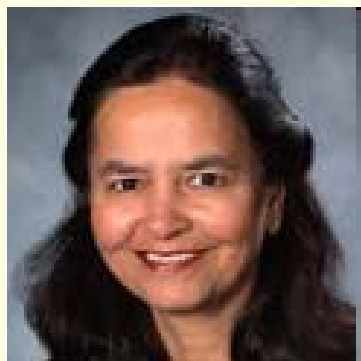

Vinita Gupta

Her Story: A Timeline of the Women Who Changed America



## *Vinita Gupta*



*Her Story: A Timeline of the Women Who Changed America*



Pitter patter  
Pitter patter  
Listen to the rain  
Pitter patter  
Pitter patter  
On the window pane





Pitter patter



Pitter pa

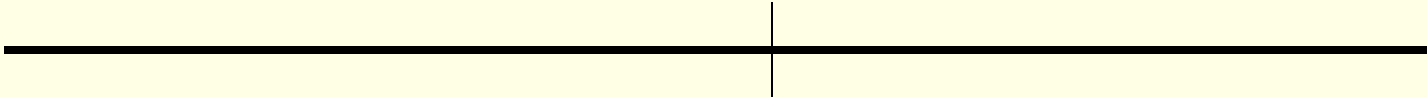

*Anita Borg*

1987



*Her Story: A Timeline of the Women Who Changed America*



*Her Story: A Timeline of the Women Who Changed America*



---

1995



*Ann Livermore*





*Her Story: A Timeline of the Women Who Changed America*

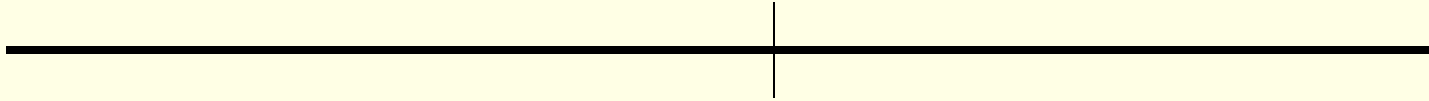

2004



*Carol Kovac*

*Her Story: A Timeline of the Women Who Changed America*



	Number of letters in first name	Prime or Composite ?	Number of letters in last name	Prime or Composite ?	Number of letters in complete name	Prime or Composite ?
Christine Ladd-Franklin						
Amalie Emmy Noether						
Grace Murray Hopper						
Euphemia Lofton Haynes						
Vinita Gupta						
Anita Borg						
Ann Livermore						
Carol Kovac						

*Her Story: A Timeline of the Women Who Changed America*

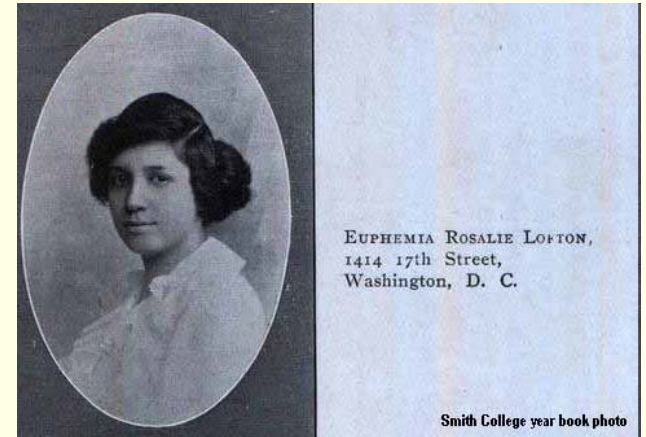
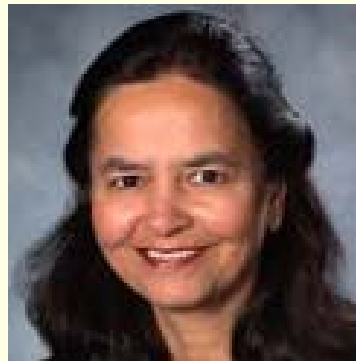

*Her Story: A Timeline of the Women Who Changed America*